

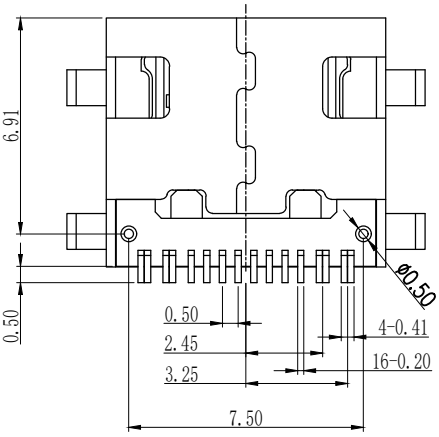

REV	DESCRIPTION	DATE	APPROVED

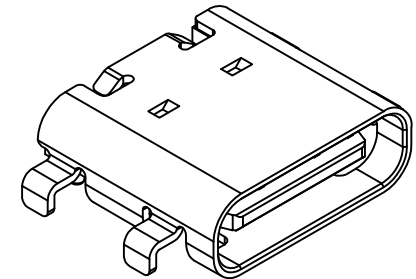
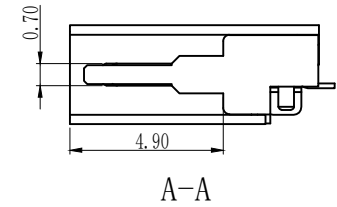
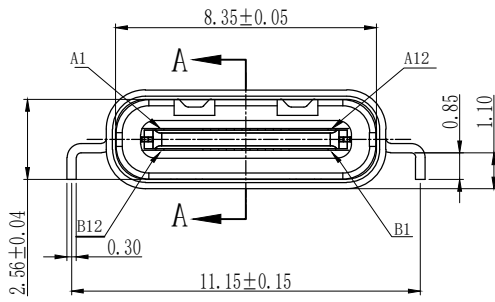
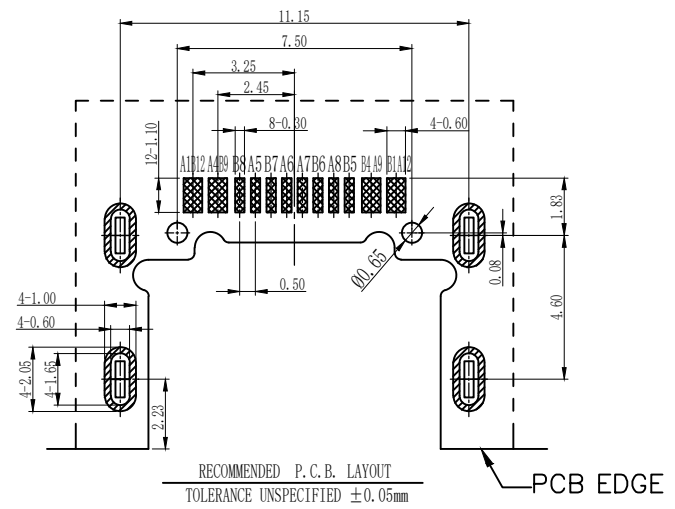
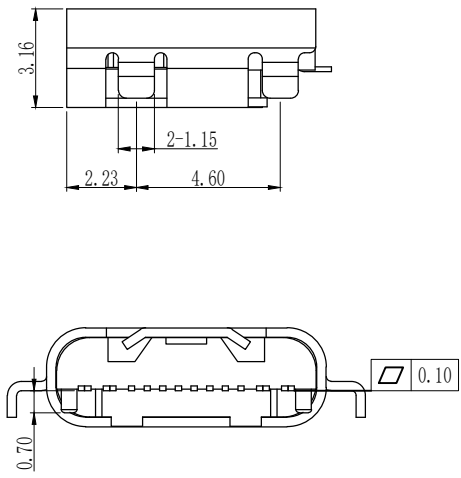
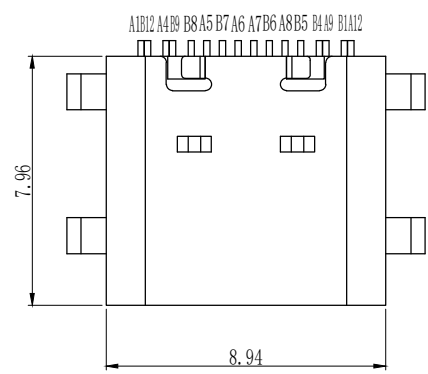

- TYPE C USB技术要求:
- 电气性能
 - 1.1 额定电流: 3A.
 - 1.2 额定电压: 5V.
 - 1.2.1 耐压: 500 V(AC) for 1 min.
 - 1.3 接触阻抗: 40mΩ Max. 可靠性和环境测试后阻抗变化不得超过10mΩ.
 - 1.4 绝缘阻抗: 100 MΩMin.
 - 机械性能
 - 2.1 插入力: 5-20N . 拔出力: 6-20N.
 - 2.2 寿命测试 10000cycles.
 - 2.3 推力: 50N min.
 - 2.4 剥离强度: 150N min.
 - 2.5 扭曲强度: 0.75Nm
 - 材料要求
 - 4.1 胶芯材料: LCP
 - 4.2 外壳材料: SUS304
 - 4.3 端子材料: C2680
 - 盐雾要求: 24H
 - 工作温度: -20° C~85° C

A1	GND	B12	GND
A4	VBUS	B9	VBUS
A5	CC1	B8	SBU2
A6	DP1	B7	DN2
A7	DN1	B6	DP2
A8	SBU1	B5	CC2
A9	VBUS	B4	VBUS
A12	GND	B1	GND
PIN	SIGNAL NAME	PIN	SIGNAL NAME

CUSTOMER DRAWING		
UNITS mm	SCALE 1:1	SHEET
PROJECTION: 	DRAW: DAP	
GENERAL TOLERANCE 0. ±0.35 0.0 ±0.25 0.00 ±0.15 0.° ±4° 0.0° ±3°	CHECK: HWT	
	APPD: HHM	

铭创科技(东莞)有限公司 Mingchuang Technology (Dongguan) Co., Ltd.	
TITLE TYPE C母座16PIN 沉板1.1 四脚插板SMT L=7.95	
MAT'L SEE TABLE	FINISH SEE TABLE
DWG. NO. 0008.TCF.16CB.X65	PART NO. _____ SIZE A4