

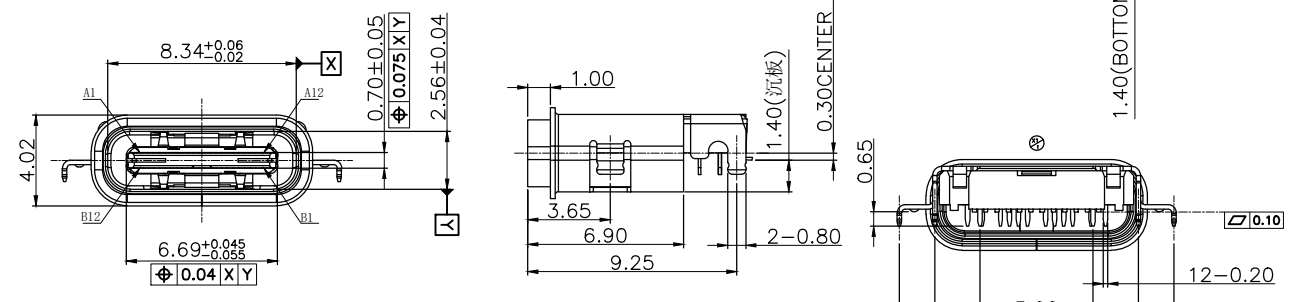

REV	DESCRIPTION	DATE	APPROVED
A	新板发行	2020.11.06	HHM

- NOTES:
- MATERIAL: SEE "TABLE 1";
  - FINISH: SEE "TABLE 1";
  - ELECTRICAL :
    - CONTACT CURRENT RATING :  
5A(VBUS PIN 1.5A/PIN),  
5A(GND PIN 1.25A/PIN MAX),0.25A/PIN(OTHER PIN).
    - INSULATION RESISTANCE :  
100 MEGAOHMS MIN. AT 250VDC.
    - DIELECTRIC WITHSTANDING VOLTAGE :  
100VAC MIN.
    - LOW LEVEL CONTACT RESISTANCE :  
INITIAL 40mΩ MAX.  
AFTER 50mΩ MAX.
  - MECHANICAL CHARACTERISTICS :
    - MATING FORCE: 5~20N.
    - UNMATING FORCE: 8~20N(INITIAL),6~20N(AFTER 10000 CYCLES);
    - DURABILITY : 10,000 MATING CYCLES.
    - OPERATING TEMPERATURE :-40°C TO +80°C

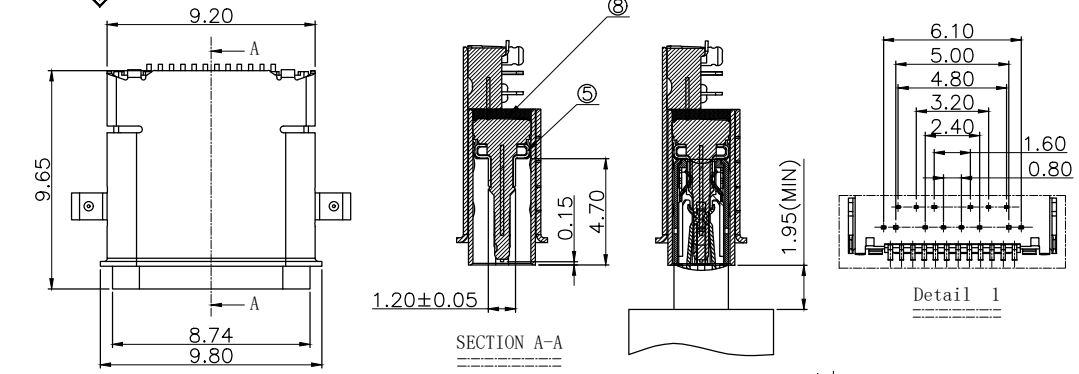

Pin	Signal Name	Mating Sequence	Pin	Signal Name	Mating Sequence
A1	GND	First	B12	GND	First
A2	SSTxp1	Second	B11	SSRxp1	Second
A3	SSTxn1	Second	B10	SSRxn1	Second
A4	Vbus	First	B9	Vbus	First
A5	CC1	Second	B8	SBU2	Second
A6	Dp1	Second	B7	Dn2	Second
A7	Dn1	Second	B6	Dp2	Second
A8	SBU1	Second	B5	CC2	Second
A9	Vbus	First	B4	Vbus	First
A10	SSRxn2	Second	B3	SSTxn2	Second
A11	SSRxp2	Second	B2	SSTxp2	Second
A12	GND	First	B1	GND	First
SHELL	GND		SHELL	GND	

TABLE 1:

NO.	PART NAME	QTY	MATERIAL	DESCRIPTION	REMARK
⑧	GLUE WATER	1	EPOXY	BLACK;	
⑦	Shell-2	1	Stainless steel	NI PLATING;	T=0.20mm
⑥	Shell-1	1	Stainless steel	NI PLATING;	T=0.20mm
⑤	GND PLATE	1	Stainless steel	NI PLATING;	T=0.10mm
④	MID PLATE	1	Stainless steel		T=0.15mm
③	Terminal-B	12	铜镍硅合金	Au:15u" PLATING;	T=0.12mm
②	Terminal-A	12	铜镍硅合金	Au:15u" PLATING;	T=0.12mm
①	Housing	1	HIGH TEMP	Black	

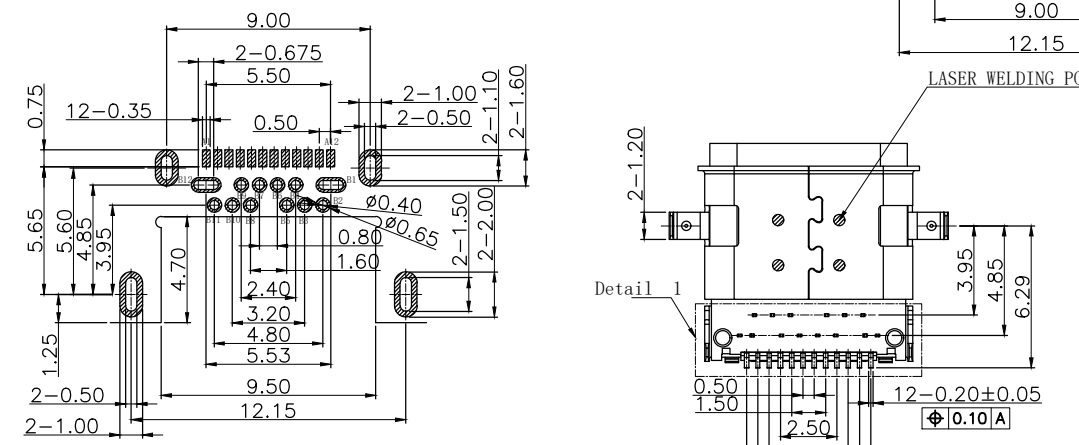

**CUSTOMER DRAWING**

**铭创科技 (东莞) 有限公司**  
Mingchuang Technology (Dongguan) Co., Ltd.

UNITS mm	SCALE 1:1	SHEET 1 OF 2	TITLE	
PROJECTION: 	DRAW: DAP		MAT'L SEE TABLE	
GENERAL TOLERANCE 0. ±0.50 0.0 ±0.30 0.00 ±0.10 0° ±2° 0.0° ±1°	CHECK: HWT	APPD: HHM	DWG. NO. 0515.WPCF.24CB.B9	FINISH SEE TABLE
			PART NO.	SIZE A4

RECOMMENDED P.C.B LAYOUT(Both sides are sample)  
Tolerance:±0.05,Thickness=0.60mm